

ANYONE CAN PLAY

VIOLIN

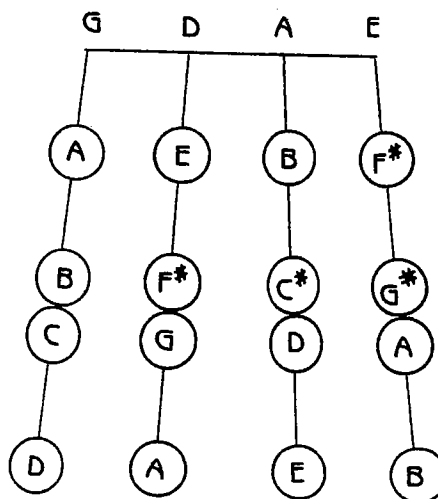

3

4

Musical notation for the violin strings. It shows a treble clef with a 4/4 time signature. The notes are grouped by string: G String (G, A, B, C), D String (D, E, F#, G), A String (A, B, C#, D), and E String (E, F#, G#, A).

Put practice tapes on your fingerboard at the measurements shown on the chart. Measure from the nut (ridge at the end of the fingerboard.) Measurements are in inches. If you have a smaller instrument, make the measurements correspondingly smaller. Be sure the tape goes straight across the fingerboard.

Fingerboard Measurements

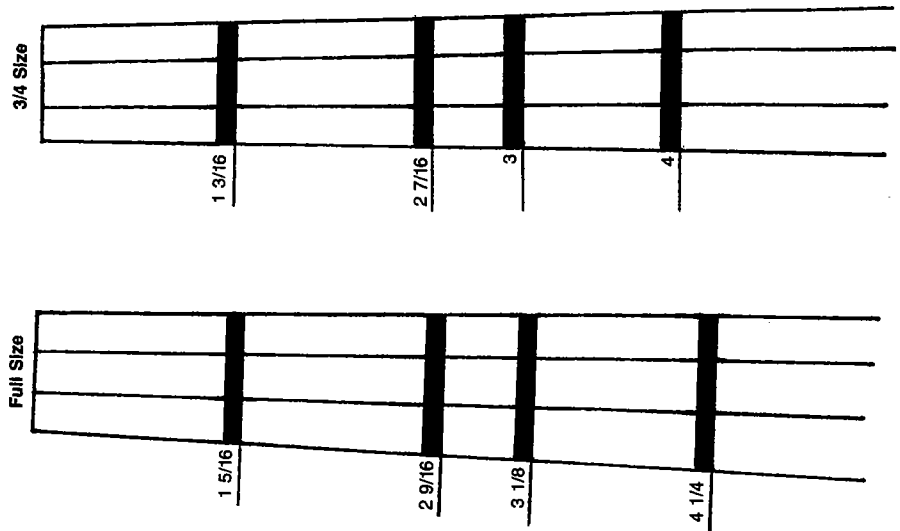

5

6

HOW TO USE THIS COURSE

First, watch the example on the video. For the beginning songs you will be talked through a slow example. You will then need to turn off the tape and practice it many times yourself (referring to the notation in the booklet.) When you have mastered the song, turn the tape back on and play along with the "up to tempo" version. If you have difficulty keeping up, practice more yourself with the booklet. The later examples on the tape don't go through the slow steps. It is assumed that you will practice slowly with the booklet, using the same practice techniques as on the earlier songs before playing with the tape.

Each day play for review all the songs you have worked on so far! This will greatly improve your playing. By the time you finish this course you will be well on your way towards a rewarding, life-long activity.

COURSE OUTLINE

1. Instrument care
2. How to tune the violin
3. How to hold the violin
4. Note reading
5. Playing pizzicato on the open strings
6. Fingering: How to put practice tapes on the violin fingerboard (see booklet reference chart)
7. Fingering: D major scale
8. How to hold and play with the bow
9. Songs:
 - Au Clair de la Lune
 - Mary Had a Little Lamb
 - Old MacDonald Had a Farm
 - Twinkle, Twinkle Little Star
 - G Major Scale
 - French Folk Tune
 - Little Brown Jug
 - A Major Scale
 - Lightly Row
 - Little Brown Jug (with 4th finger)
 - Go Tell Aunt Rhody

7

OPEN STRING NOTES

E E E E A A A A D D D D G G G G G G G G

D D D D A A A A E E E E

D MAJOR SCALE

D D D D E E E E F# F# F# F# G G G G A A A A

B B B B C# C# C# C# D D D D D D D D C# C# C# C# B B B B

A A A A G G G G F# F# F# F# E E E E D D D D

AU CLAIR DE LA LUNE (D Major)

D D D E F# E D F# E E D

AU CLAIR DE LA LUNE (A Major)

A musical staff in treble clef with a key signature of two sharps (F# and C#) and a 4/4 time signature. The notes are: A4, A4, A4, B4, C#5, B4, A4, C#5, B4, B4, A4. Above the staff, the following chord labels are written: A A A B, C#, B, A C# B B, A.

11

12

OPEN STRING NOTES

A musical staff in treble clef with a key signature of two sharps and a 4/4 time signature. The notes are: E4, E4, E4, E4, E4, E4, A4, A4, A4, A4, A4, A4, D4, D4, D4, D4, D4, D4, G4, G4, G4, G4, G4, G4, G4, G4, D4, D4, A4, A4, A4, A4, A4, A4, E4, E4, E4, E4, E4, E4. Above the staff, the following chord labels are written: E E E E, E E, A A A A, A A, D D D D, D D, G G G G, G G, G G G G, G G, G G G G, D D D D, D D, A A A A, A A, E E E E, E, E.

OPEN STRING NOTES WITH A NEW RHYTHM

A musical staff in treble clef with a key signature of two sharps and a 4/4 time signature. The notes are: E4, E4, E4, E4, E4, E4, A4, A4, A4, A4, A4, A4, D4, D4, D4, D4, D4, D4, G4, G4, G4, G4, G4, G4, G4, G4, D4, D4, A4, A4, A4, A4, A4, A4, E4, E4, E4, E4, E4, E4. Above the staff, the following chord labels are written: E E E E, E E, A A A A, A A, D D D D, D D, G G G G, G G, G G G G, D D D D, D D, A A A A, A A, E E E E, E, E.

13

OPEN STRING NOTES WITH ANOTHER RHYTHM

Three staves of musical notation. The first staff is a treble clef with a 4/4 time signature, showing a sequence of notes on the open strings (E, A, D, G, B, E) in a specific rhythmic pattern. The second and third staves show the same notes on the open strings, but with a different rhythmic pattern, likely demonstrating how the same notes can be played in different ways.

MARY HAD A LITTLE LAMB

Musical notation for the song 'Mary Had a Little Lamb'. It consists of two staves. The first staff is a treble clef with a 4/4 time signature and a key signature of one sharp (F#). The notes are labeled with their corresponding letter names: F# E D E, F# F# F#, E E E, F# A A, and F# E D E. The second staff shows the same notes on the open strings, with labels F# F# F# F#, E E F# E, and D.

D MAJOR SCALE IN A NEW RHYTHM

Six staves of musical notation showing the D major scale (D, E, F#, G, A, B, C#, D) in a new rhythm. The first staff is a treble clef with a 4/4 time signature. The subsequent staves show the same scale notes on the open strings, but with a different rhythmic pattern, demonstrating how the same notes can be played in different ways.

OLD MACDONALD HAD A FARM

This song uses the notes of the D scale. Try learning it without writing in the note names.

Musical notation for 'Old MacDonald Had a Farm' in D major, 4/4 time. It consists of three staves. The first staff begins with a treble clef, a key signature of one sharp (F#), and a 4/4 time signature. The melody is written in quarter notes and eighth notes. The second and third staves continue the melody.

17

D MAJOR SCALE IN ANOTHER RHYTHM

18

Musical notation for 'D Major Scale in Another Rhythm' in D major, 4/4 time. It consists of five staves. The first staff begins with a treble clef, a key signature of one sharp (F#), and a 4/4 time signature. The melody is written in quarter notes and eighth notes, demonstrating a different rhythmic pattern than the previous piece. The second through fifth staves continue the scale.

TWINKLE, TWINKLE LITTLE STAR

Musical notation for 'Twinkle, Twinkle Little Star' in D major, 4/4 time. It consists of three staves. The first staff begins with a treble clef, a key signature of one sharp (F#), and a 4/4 time signature. The melody is written in quarter notes and eighth notes. The second and third staves continue the melody.

19

G MAJOR SCALE

Musical notation for G Major Scale, page 20. It consists of three staves of music. The first staff has notes G, A, B, C, D with fingerings 3 and 4. The second staff has notes E, F#, G, G, F#, E. The third staff has notes D, C, B, A, G.

FRENCH FOLK TUNE

Musical notation for French Folk Tune, page 21. It consists of four staves of music. The first staff has notes G, F#, E, G, D, C. The second staff has notes B, A, G, G, A, B, G, A, B, G, A, B. The third staff has notes C, A, B, C, A, B, C, A, B, C, D, G, F#, E. The fourth staff has notes D, C, B, A, G, A, G.

G MAJOR SCALE (all notes down bow)

Musical notation for G Major Scale (all notes down bow), page 22. It consists of three staves of music. The first staff has notes G, A, B, C, D, E, F#, G with fingerings 4 and 4, and a box with "etc." above it. The second and third staves continue the scale with notes down to G.

LITTLE BROWN JUG

Musical notation for 'LITTLE BROWN JUG' in 4/4 time, key of A major. It consists of three staves of music. The first staff has a treble clef and a key signature of two sharps (F# and C#). The second and third staves have bass clefs. The music features a simple melody with a bass accompaniment.

23

24

A MAJOR SCALE

Musical notation for the A Major Scale in 4/4 time, key of A major. It consists of three staves of music. The first staff has a treble clef and a key signature of two sharps (F# and C#). The second and third staves have bass clefs. The scale is written in a stepwise fashion, with notes labeled above and below the staff.

A A A A B B B B C# C# C# C# D D D D E E E E

F# F# F# F# G# G# G# G# A A A A A A A A G# G# G# G# F# F# F# F#

E E E E D D D D C# C# C# C# B B B B A A A A

LIGHTLY ROW

Musical notation for 'LIGHTLY ROW' in 4/4 time, key of A major. It consists of three staves of music. The first staff has a treble clef and a key signature of two sharps (F# and C#). The second and third staves have bass clefs. The music features a simple melody with a bass accompaniment.

E C# C# D B B A B C# D E E E E C# C# C#

D B B B A C# E E C# C# C# B B B B B C# D C# C# C# C#

C# D E E C# C# C# D B B B A C# E E C# C# C#

25

LITTLE BROWN JUG (using the 4th finger)

Musical score for 'Little Brown Jug' in 4/4 time, key of G major. The score consists of three staves. The first staff begins with a treble clef, a key signature of one sharp (F#), and a 4/4 time signature. The melody is written in quarter notes and eighth notes. The second and third staves provide accompaniment, primarily using chords and single notes. Fingerings are indicated by the number '4' above notes, and a square box symbol is used above certain notes in the first and second staves.

A MAJOR SCALE IN A NEW RHYTHM

Musical score for 'A Major Scale in a New Rhythm' in 4/4 time, key of G major. The score consists of three staves. The first staff shows the G major scale (G-A-B-A-G-F#-E-D) in a rhythmic pattern of quarter and eighth notes. The second and third staves provide accompaniment with chords and single notes.

GO TELL AUNT RHODY

Musical score for 'Go Tell Aunt Rhody' in 4/4 time, key of G major. The score consists of four staves. The first staff begins with a treble clef, a key signature of one sharp (F#), and a 4/4 time signature. The melody is written in quarter notes. The second, third, and fourth staves provide accompaniment with chords and single notes.